

# POW - R - ARC Application Guide – Speed & Feed (metric)

ISO Code	Work Material	Type of Cut	Axial DOC	Radial DOC	No. of Flutes	Speed (M/min)	Feed (MM per Tooth)				
							6	10	12	16	20
<b>K</b>	Cast Iron- Gray ASTM-A48 Class 20, 25,30,35 & 40	Ball 3D and Tip Machining	0.50 x D	0.080 x D	6, 8	143	.03000	.05000	.06000	.08000	.10000
		Slotting	0.040 x D	1.000 x D	6, 8	137	.04080	.06800	.08160	.10880	.13600
		Finishing 3D Facing	0.03 x D	0.020 x D	6, 8	168	.04800	.08000	.09600	.12800	.16000
		Peripheral Machining	2.50 x D	0.080 x D	6, 8	131	.04800	.08000	.09600	.12800	.16000
	Cast Iron- Ductile	Ball 3D and Tip Machining	0.50 x D	0.080 x D	6, 8	134	.02760	.04600	.05520	.07360	.09200
		Slotting	0.040 x D	1.000 x D	6, 8	119	.03600	.06000	.07200	.09600	.12000
		Finishing 3D Facing	0.03 x D	0.020 x D	6, 8	163	.04320	.07200	.08640	.11520	.14400
		Peripheral Machining	2.50 x D	0.080 x D	6, 8	128	.03960	.06600	.07920	.10560	.13200
	Cast Iron- Malleable	Ball 3D and Tip Machining	0.50 x D	0.080 x D	6, 8	134	.02640	.04400	.05280	.07040	.08800
		Slotting	0.040 x D	1.000 x D	6, 8	125	.03480	.05800	.06960	.09280	.11600
		Finishing 3D Facing	0.03 x D	0.020 x D	6, 8	163	.03840	.06400	.07680	.10240	.12800
		Peripheral Machining	2.50 x D	0.080 x D	6, 8	128	.03840	.06400	.07680	.10240	.12800
<b>P</b>	Low Carbon Steel ≤38 HRC 1018, 1020, 12L14, 5120, 8620	Ball 3D and Tip Machining	0.50 x D	0.080 x D	6, 8	154	.02760	.04600	.05520	.07360	.09200
		Slotting	0.040 x D	1.000 x D	6, 8	152	.04200	.07000	.08400	.11200	.14000
		Finishing 3D Facing	0.03 x D	0.020 x D	6, 8	178	.04680	.07800	.09360	.12480	.15600
		Peripheral Machining	2.50 x D	0.080 x D	6, 8	158	.04920	.08200	.09840	.13120	.16400
	Medium Carbon Steel ≤48 HRC 1045, 4140, 4340, 5140	Ball 3D and Tip Machining	0.50 x D	0.080 x D	6, 8	143	.02640	.04400	.05280	.07040	.08800
		Slotting	0.040 x D	1.000 x D	6, 8	143	.03720	.06200	.07440	.09920	.12400
		Finishing 3D Facing	0.03 x D	0.020 x D	6, 8	168	.04320	.07200	.08640	.11520	.14400
		Peripheral Machining	2.50 x D	0.080 x D	6, 8	148	.04800	.08000	.09600	.12800	.16000
	Tool & Die Steels ≤40 HRC A2, D2, O1, S7, P20, H13	Ball 3D and Tip Machining	0.50 x D	0.080 x D	6, 8	137	.02400	.04000	.04800	.06400	.08000
		Slotting	0.040 x D	1.000 x D	6, 8	130	.03600	.06000	.07200	.09600	.12000
		Finishing 3D Facing	0.03 x D	0.020 x D	6, 8	155	.03600	.06000	.07200	.09600	.12000
		Peripheral Machining	2.50 x D	0.075 x D	6, 8	137	.04320	.07200	.08640	.11520	.14400
<b>H</b>	Tool & Die Steels 40-48 HRC	Ball 3D and Tip Machining	0.50 x D	0.065 x D	6, 8	116	.02040	.03400	.04080	.05440	.06800
		Slotting	0.030 x D	1.000 x D	6, 8	114	.02640	.04400	.05280	.07040	.08800
		Finishing 3D Facing	0.02 x D	0.020 x D	6, 8	137	.03240	.05400	.06480	.08640	.10800
		Peripheral Machining	2.00 x D	0.065 x D	6, 8	122	.02640	.04400	.05280	.07040	.08800
<b>M</b>	Martensitic & Ferritic Stainless Steels 410, 416, 440	Ball 3D and Tip Machining	0.50 x D	0.080 x D	6, 8	158	.01920	.03200	.03840	.05120	.06400
		Slotting	0.040 x D	1.000 x D	6, 8	142	.03480	.05800	.06960	.09280	.11600
		Finishing 3D Facing	0.03 x D	0.020 x D	6, 8	165	.04320	.07200	.08640	.11520	.14400
		Peripheral Machining	2.50 x D	0.075 x D	6, 8	149	.04920	.08200	.09840	.13120	.16400
	Austenitic Stainless Steels FeNi Alloys 303, 304, 316, Invar, Kovar	Ball 3D and Tip Machining	0.50 x D	0.070 x D	6, 8	152	.01800	.03000	.03600	.04800	.06000
		Slotting	0.040 x D	1.000 x D	6, 8	130	.03120	.05200	.06240	.08320	.10400
		Finishing 3D Facing	0.03 x D	0.020 x D	6, 8	155	.03960	.06600	.07920	.10560	.13200
		Peripheral Machining	2.50 x D	0.075 x D	6, 8	149	.04440	.07400	.08880	.11840	.14800
	Precipitation Hardening Stainless Steel 17-4, 15-5, 13-8	Ball 3D and Tip Machining	0.50 x D	0.080 x D	6, 8	149	.01800	.03000	.03600	.04800	.06000
		Slotting	0.040 x D	1.000 x D	6, 8	119	.02520	.04200	.05040	.06720	.08400
		Finishing 3D Facing	0.030 x D	0.020 x D	6, 8	143	.03360	.05600	.06720	.08960	.11200
		Peripheral Machining	2.00 x D	0.065 x D	6, 8	146	.03600	.06000	.07200	.09600	.12000

D = Tool Diameter

# POW - R - ARC Application Guide – Speed & Feed (metric)

ISO Code	Work Material	Type of Cut	Axial DOC	Radial DOC	No. of Flutes	Speed (M/min)	Feed (MM per Tooth)				
							6	10	12	16	20
S	Titanium Alloys 6AL-4V, 6-2-4	Ball 3D and Tip Machining	0.50 x D	0.080 x D	6, 8	119	.04800	.08000	.09600	.12800	.16000
		Slotting	0.040 x D	1.000 x D	6, 8	120	.02400	.04000	.04800	.06400	.08000
		Finishing 3D Facing	0.030 x D	0.020 x D	6, 8	137	.03120	.05200	.06240	.08320	.10400
		Peripheral Machining	2.50 x D	0.080 x D	6, 8	134	.04800	.08000	.09600	.12800	.16000
	Difficult to machine titanium alloys 10-2-3	Ball 3D and Tip Machining	0.45 x D	0.070 x D	6, 8	98	.04200	.07000	.08400	.11200	.14000
		Slotting	0.035 x D	1.000 x D	6, 8	98	.01800	.03000	.03600	.04800	.06000
		Finishing 3D Facing	0.030 x D	0.020 x D	6, 8	116	.02760	.04600	.05520	.07360	.09200
		Peripheral Machining	2.50 x D	0.080 x D	6, 8	122	.04200	.07000	.08400	.11200	.14000
	Nickel Based Super Alloys Hastalloy, Waspalloy	Ball 3D and Tip Machining	0.50 x D	0.065 x D	6, 8	99	.03600	.06000	.07200	.09600	.12000
		Slotting	0.030 x D	1.000 x D	6, 8	107	.19200	.32000	.38400	.51200	.64000
		Finishing 3D Facing	0.025 x D	0.020 x D	6, 8	119	.02880	.04800	.05760	.07680	.09600
		Peripheral Machining	2.50 x D	0.080 x D	6, 8	99	.03600	.06000	.07200	.09600	.12000
	Nickel Chromium based Super Alloys Inconel 718, Rene 88	Ball 3D and Tip Machining	0.50 x D	0.075 x D	6, 8	61	.04800	.08000	.09600	.12800	.16000
		Slotting	0.025 x D	1.000 x D	6, 8	34	.01680	.02800	.03360	.04480	.05600
		Finishing 3D Facing	0.025 x D	0.020 x D	6, 8	38	.04080	.06800	.08160	.10880	.13600
		Peripheral Machining	1.50 x D	0.070 x D	6, 8	61	.04200	.07000	.08400	.11200	.14000
N	Aluminum alloys 2024, 6061, 7075	Ball 3D and Tip Machining	0.50 x D	0.050 x D	6, 8	366	.04800	.08000	.09600	.12800	.16000
		Slotting	0.040 x D	1.000 x D	6, 8	366	.04320	.07200	.08640	.11520	.14400
		Finishing 3D Facing	0.03 x D	0.020 x D	6, 8	457	.03600	.06000	.07200	.09600	.12000
		Peripheral Machining	2.50 x D	0.070 x D	6, 8	427	.03600	.06000	.07200	.09600	.12000
	High Silicon Aluminum alloys A380, A390	Ball 3D and Tip Machining	0.50 x D	0.050 x D	6, 8	294	.05040	.08400	.10080	.13440	.16800
		Slotting	0.040 x D	1.000 x D	6, 8	274	.04560	.07600	.09120	.12160	.15200
		Finishing 3D Facing	0.03 x D	0.020 x D	6, 8	351	.03600	.06000	.07200	.09600	.12000
		Peripheral Machining	2.50 x D	0.070 x D	6, 8	366	.03720	.06200	.07440	.09920	.12400
	Magnesium alloys	Ball 3D and Tip Machining	0.50 x D	0.050 x D	6, 8	366	.04800	.08000	.09600	.12800	.16000
		Slotting	0.040 x D	1.000 x D	6, 8	366	.04320	.07200	.08640	.11520	.14400
		Finishing 3D Facing	0.03 x D	0.020 x D	6, 8	427	.03600	.06000	.07200	.09600	.12000
		Peripheral Machining	2.50 x D	0.070 x D	6, 8	427	.03600	.06000	.07200	.09600	.12000
	Copper alloys, Brass	Ball 3D and Tip Machining	0.50 x D	0.050 x D	6, 8	219	.04560	.07600	.09120	.12160	.15200
		Slotting	0.040 x D	1.000 x D	6, 8	251	.04080	.06800	.08160	.10880	.13600
		Finishing 3D Facing	0.030 x D	0.020 x D	6, 8	262	.03360	.05600	.06720	.08960	.11200
		Peripheral Machining	2.50 x D	0.070 x D	6, 8	335	.03120	.05200	.06240	.08320	.10400
	Bronze	Ball 3D and Tip Machining	0.50 x D	0.050 x D	6, 8	218	.04440	.07400	.08880	.11840	.14800
		Slotting	0.040 x D	1.000 x D	6, 8	251	.03960	.06600	.07920	.10560	.13200
		Finishing 3D Facing	0.030 x D	0.020 x D	6, 8	261	.03000	.05000	.06000	.08000	.10000
		Peripheral Machining	2.50 x D	0.070 x D	6, 8	305	.03000	.05000	.06000	.08000	.10000
	Composites, Plastics, Fiberglass	Ball 3D and Tip Machining	0.50 x D	0.050 x D	6, 8	335	.05040	.08400	.10080	.13440	.16800
		Slotting	0.040 x D	1.000 x D	6, 8	274	.04560	.07600	.09120	.12160	.15200
		Finishing 3D Facing	0.03 x D	0.020 x D	6, 8	427	.03720	.06200	.07440	.09920	.12400
		Peripheral Machining	2.50 x D	0.070 x D	6, 8	366	.04800	.08000	.09600	.12800	.16000

D = Tool Diameter

## ADJUSTMENTS FOR LONG REACH APPLICATIONS

Using long-length tools increases the amount of tool projection from the tool holder and the spindle. As the tool projection increases so does the amount of tool deflection. Tool deflection causes chatter, resulting in poor surface finish and reduced tool life. Tool options that help minimize tool deflection in long projection applications are:

- Use a larger diameter tool for the operation. Larger tools have larger cores, which reduces deflection.
- Use a tool with a necked shank, which shortens the flute length and increases the core strength of the end mill.

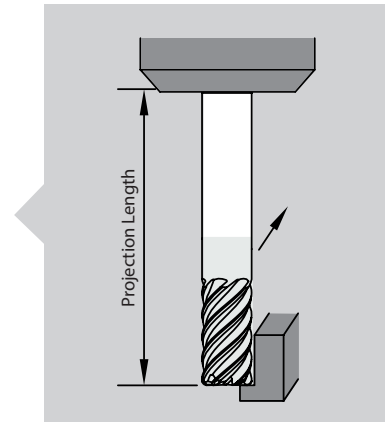

### Speed and feed adjustments for long tool projections:

Adjustments must be made to reduce chatter and maximize tool life when using long length tools. The adjustments below are based on the total amount of tool projection and use the speed and feed data found in the application charts for each tool series.

Projection	SFM / MMPM	Feed
> 1.25 to 3 x D	SFM or M/min x .95	IPT or MMPT x .95
> 3 to 4 x D	SFM or M/min x .90	IPT or MMPT x .90
> 4 to 5 x D	SFM or MMPM x .80	IPT or MMPT x .80
> 5 to 6 x D	SFM or MMPM x .70	IPT or MMPT x .70

D = Tool diameter  
 IPT = Inch per tooth  
 MMPT = Millimeter per tooth  
 SFM = Surface feet per minute  
 MPM = Millimeters per minute

**IMPORTANT NOTES:** No adjustments are necessary when using the speed and feed data for HEM tool paths found in the charts for any of the POW•R•PATH and enDURO end mills. Use the data directly from the charts. This applies only when using HEM tool paths.

The M223 and M233 have the long projections adjustments already incorporated into the speed and feed charts for those series. Use the data directly from the charts with no adjustments for long projections.

### Tool Tip: Eliminate Wall Taper When Finishing.

#### STEP 1:

Run a climb cut finish pass using speed, feed and step-over values (RDOC) from the speed and feed charts. Adjust for tool projection if needed.

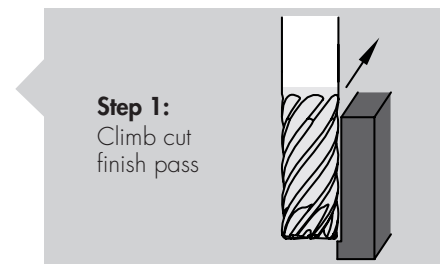

#### STEP 2:

Re-run the path using the same speeds and feeds but in a conventional cut direction. Simply retrace the prior finish pass; do not program to remove more stock. This skim pass, traveling in the opposite direction of the first pass, will help eliminate wall taper caused by tool deflection during the first pass.

